

STEERING REBUILDERS & TRUCK PARTS, INC.

764 CR 383 - CLEVELAND, TEXAS 77327

Ph: (281) 386-7229 Fax #281/432-1332 Em: rwhitten_srtp@yahoo.com

CORE CREDIT GUIDELINES

May 2013

STEERING REBUILDERS & TRUCK PARTS, INC.

764 CR 383 - CLEVELAND, TEXAS 77327

Ph: (281) 386-7229 Fax #281/432-1332 Em: rwhitten_srtp@yahoo.com

“CORE” ACCEPTANCE CRITERIA

ATTENTION CUSTOMER - USE THE INFORMATION LISTED BELOW TO DETERMINE CONDITION OF YOUR CORE BEFORE RETURNING IT TO THE FACTORY OR YOUR LOCAL DISTRIBUTOR. INSPECT ALL CORES FOR THE FOLLOWING:

- 1) Wire brush and verify part number on core. It must match original unit sold. *(If not, Deduct 1/2 core credit)*
- 2) Verify that unit is complete, not disassembled. *(If disassembled, Deduct 1/2 core credit)*
- 3) Check input shaft for the following: (A) Cracks, twist in splines or has been sheared off. *(If cracks, twist or sheared off, Deduct 3/4 core credit)* (B) Excessive spline wear. *(Deduct 1/2 core credit)* (C) Yoke has been welded to input. *(Deduct 1/2 core credit)*
- 4) Check Sector Shaft for the following: (A) Cracks, twist in splines or has been sheared off. *(If cracks, twist or sheared off, Deduct 3/4 core credit)* (B) Excessive spline wear. *(Deduct 1/2 core credit)* (C) Pitman arm welded to sector. *(Deduct 1/2 core credit)*
- 5) Make sure Mounting bolt holes are not stripped or have torch damage. *(Deduct 1/2 core credit)*
- 6) Input and sector shafts must turn thru from end to end. Verify the sector shaft is turning when the input shaft is turned. Input and Sector shaft must have same number of turns and turn thru evenly. Rotate input shaft 3-6 turns using a ratchet and 12 pt socket OR a 12 pt box end wrench. *(If not, Deduct 3/4 core credit)*
- 7) Make sure Housing has no crack. Clean and inspect housing *(If cracked, Deduct 3/4 core credit)*
- 8) Check all ports to make sure they are not stripped. *(If stripped, Deduct 1/2 core credit)*
- 9) Used oil must be drained from core. Do this by turning input shaft from end to end at least a minimum of 5 complete turns. Plastic port plugs must be installed. If necessary, put core in Heavy Duty Plastic Bag to keep from Leaking. *(Deduct \$30.00 for core not being drained and plugged)*
- 10) ALL CORES MUST BE RETURNED WITH A COPY OF ORIGINAL INVOICE OR A FEE OF \$20.00 PER UNIT WILL BE DEDUCTED FROM CORE CREDIT.
- 11) Customer is responsible for all freight charges when returning core, unless other arrangements have been made.

GEARS
(Typical Illustration only)

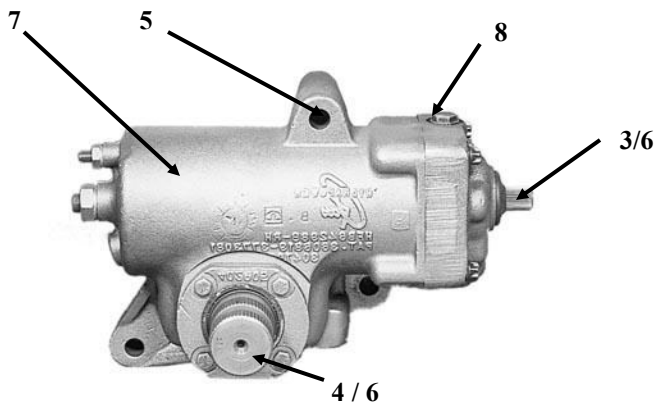

PUMPS
(Typical Illustration only)

